A modern kitchen with grey cabinetry, white countertops, and a white subway tile backsplash. The kitchen features a large island with a white countertop and a small tree on it. There are two skylights in the ceiling. The floor is made of light-colored wood. A yellow circle is overlaid on the center of the image, containing the text.

**A GUIDE TO**  
Product Installation,  
Dimensions &  
Configurations

**MKM**

Accent Collection

# CONTENTS

<b>Installation Heights</b> .....	3
<b>Door Configurations</b> .....	4
<b>Cabinets</b>	
Installation Fittings.....	5
Appliance Housing Drill Holes Guide.....	6
L-shape Corners with Bi-fold Doors.....	7
Belfast Units.....	8
Boiler Housing.....	8
Bridging Units.....	8
Wall Microwave Housing.....	9
<b>Corner Planning</b>	
Corner Base Units.....	11
Guide to Lh/Rh Wirework Units.....	11
Corner Wall Units.....	12
<b>Curved Units</b> .....	12
<b>End Panels</b>	
Wall End Panel Heights.....	13
End Panel Grain / T&G Direction.....	14
<b>Drawers</b>	
Drawer Front Marking Tool.....	15
SmartLarder.....	15
Internal Drawers.....	16
Drawer Runner Positions.....	17

Release date: July 2020

# INSTALLATION HEIGHTS

**Standard Height Installation**  
1970mm

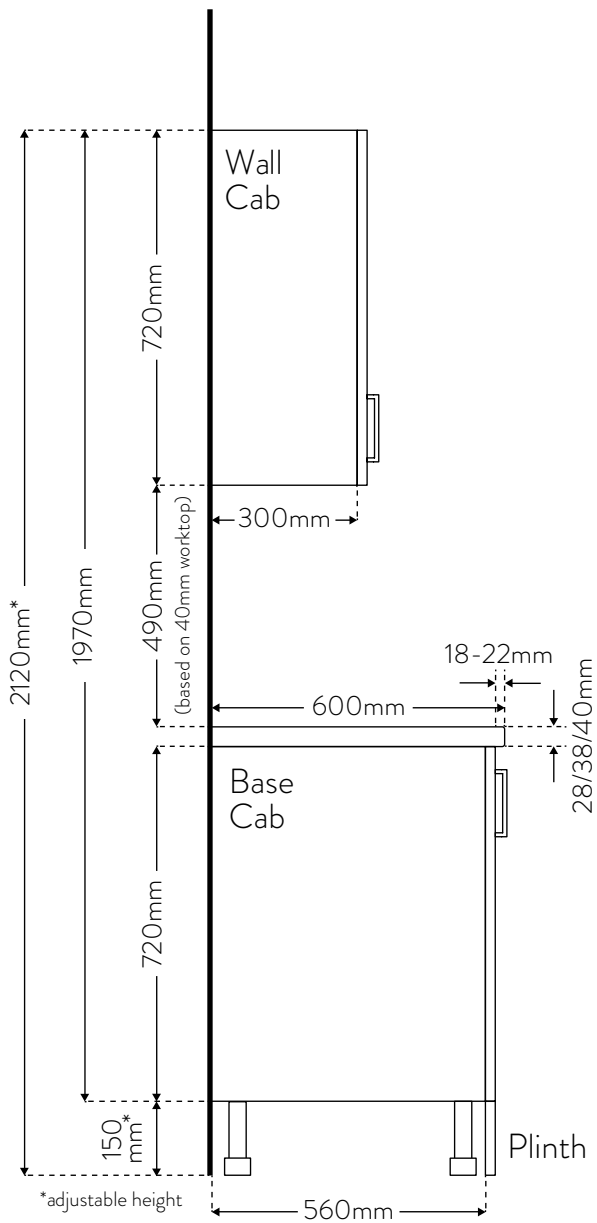

**Extra Tall Height Installation**  
2150mm

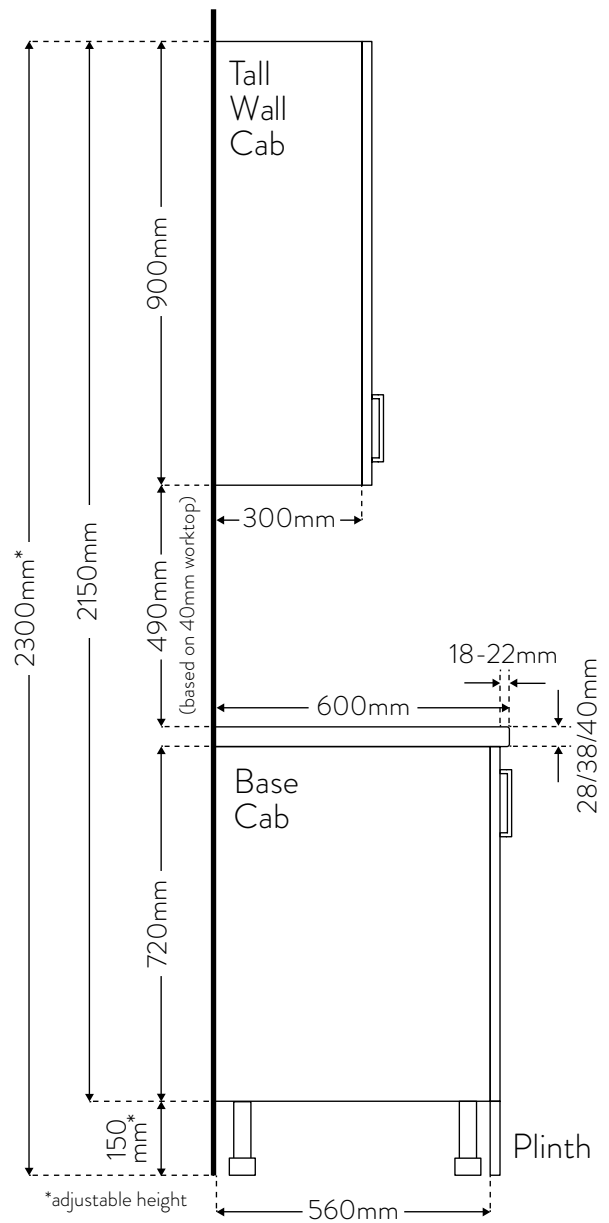

# DOOR CONFIGURATIONS

## Standard units

### BASE & WALL UNIT CONFIGURATIONS

Standard height installation (1970mm) & extra tall height installation (2150mm).

All dimensions shown in mm.

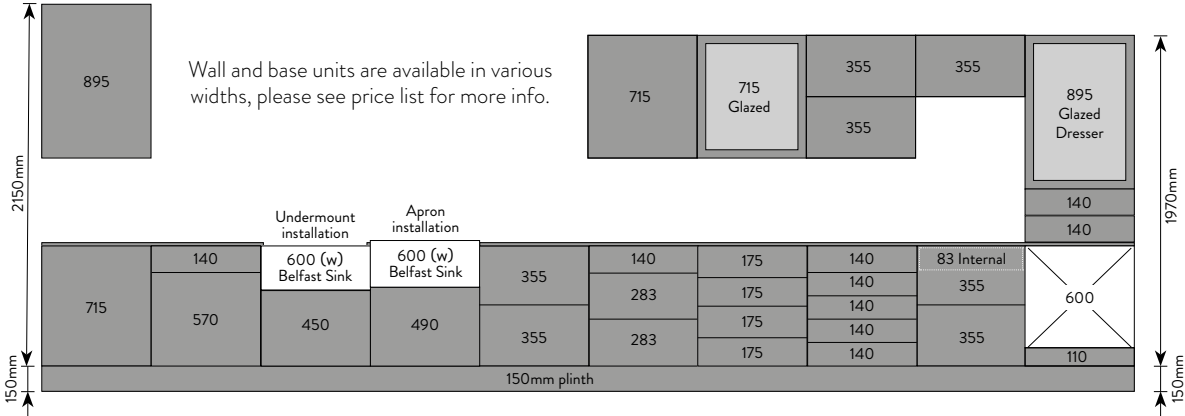

### LARDER & APPLIANCE UNIT CONFIGURATIONS

Standard height installation (1970mm).

This code is unique to this appliance unit & added to the end of the order code.

30FHD-60FHD	L30-L60	FF50	FF70	FF90	TOVENA	TOVENB	TOVENC	TOVEND	TOVENE	TOVENF
1965 Available widths: 300 400 500 600	1245	980	1245	175	900	600	380	460	900	600
	Available widths: 300 400 500 600			490						
	715		715	895	570	715	490	450	283	355
				895					283	355
150mm plinth										
Larder Unit, Full Height Doors (Slab only)	Larder Unit 70/30	Fridge / Freezer 50/50 (980 doors)	Fridge / Freezer 70/30	Fridge / Freezer 50/50 (895 doors)	Double Oven	Single Oven	Single Oven & 380mm Micro	Single Oven & 460mm Micro	Dble Oven & 283mm drawers	Sgle Oven & 355mm drawers

### EXTRA TALL LARDER & APPLIANCE UNIT CONFIGURATIONS

Extra tall height installation (2150mm).

This code is unique to this appliance unit & added to the end of the order

TL30-TL60	TFF50	TFF70	TTOVENA	TTOVENB	TTOVENC	TTOVEND	TTOVENE	TTOVENF
1245 Available widths: 300 400 500 600	980	1245	175	900	380	460	900	600
			715					
			110	filler	filler	filler	filler	110
			600	900	600	600	900	600
			715	570	570	140	283	355
			895	895	895	450	283	355
150mm plinth								
Larder Unit	Fridge / Freezer 50/50	Fridge / Freezer 70/30	Single Oven	Double Oven	Single Oven & 380mm Micro	Single Oven & 460mm Micro	Dble Oven & 283mm drawers	Sgle Oven & 355mm drawers

**NB:** This page is to show door configurations only. Appliance heights will vary and may have an impact on filler / door sizes. **Please check appliance heights and specifications** before purchasing and installing any units to ensure they fit the door configurations specified and are suitable for your requirements.

## Installation fittings

Example pack contents for standard Double Wall and Double Base cabinets.



**Hinge pack:**

2 sets of hinges, 16mm screws, 18mm mounting plates with Euro screws, hinge plate covers and cam plate covers.

### Basic installation:

1. Push the wall hangers into the sides of the back of the wall units.
2. Attach the wall plates to wall (screws & plugs not supplied).
3. Hang wall unit on to wall plates.

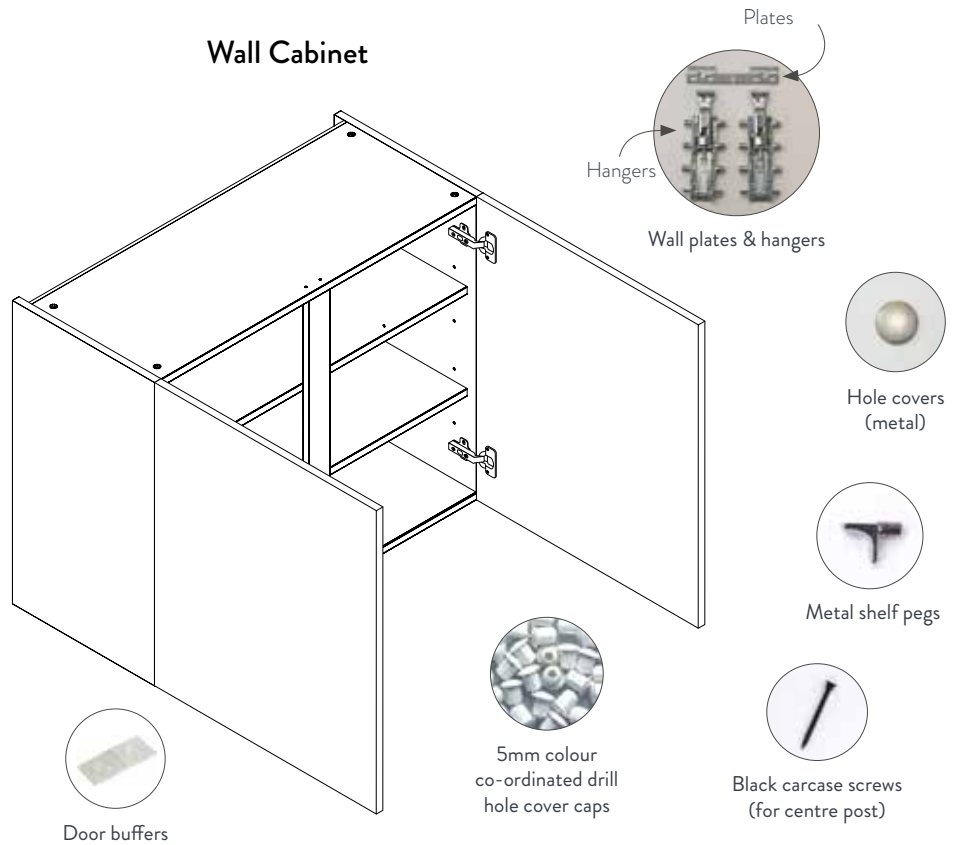

**Hinge pack:**

2 sets of hinges, 16mm screws, 18mm mounting plates with Euro screws, hinge plate covers and cam plate covers.



**L-brackets**  
25 x 25mm



**Cabinet legs & plinth clips**

### Basic installation:

1. Push against the wall.
2. Secure to wall using L-brackets.

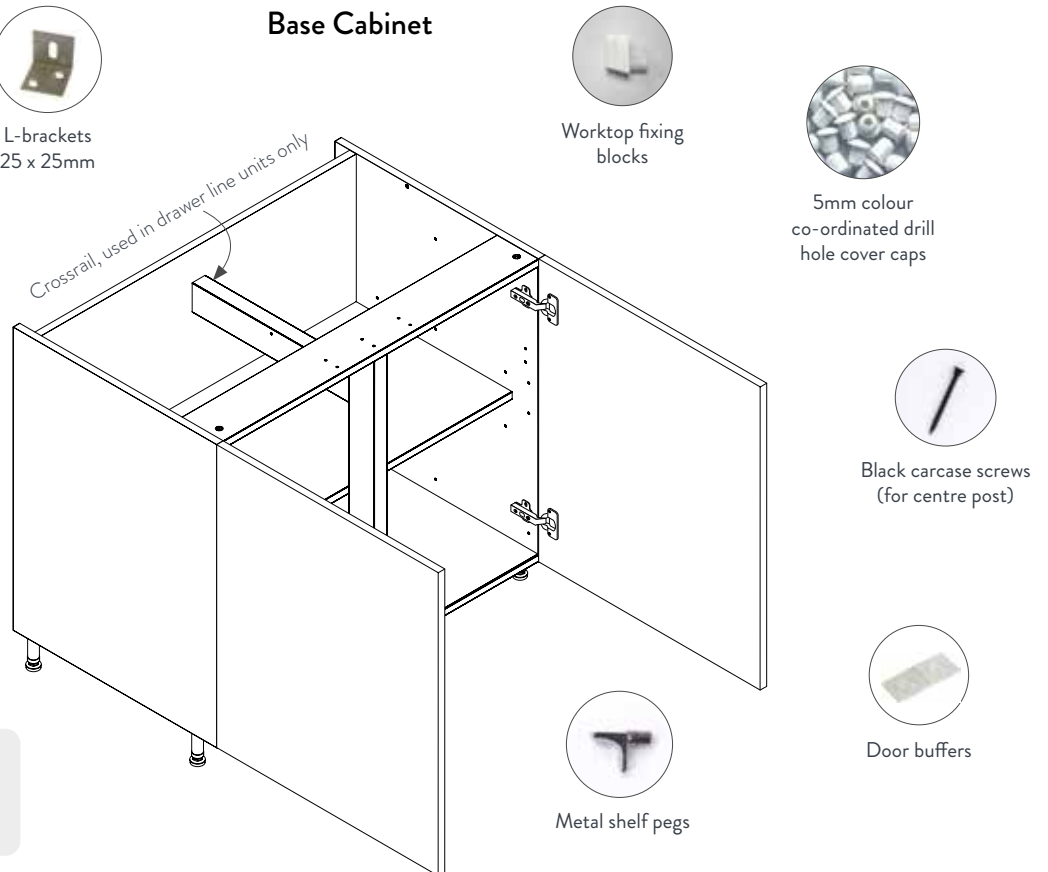

## Appliance housing drill holes guide

### Shelf positions, hinge holes & drawer runners

- Our appliance housings come with **pre-drilled holes** for shelf positions, door hinges and drawer runners, covering most of the appliance unit configurations available in our price list.
- Use the appliance housing guides (see links below) to locate pre-drilled holes for your appliance units and to find info about any holes you need to drill yourself.

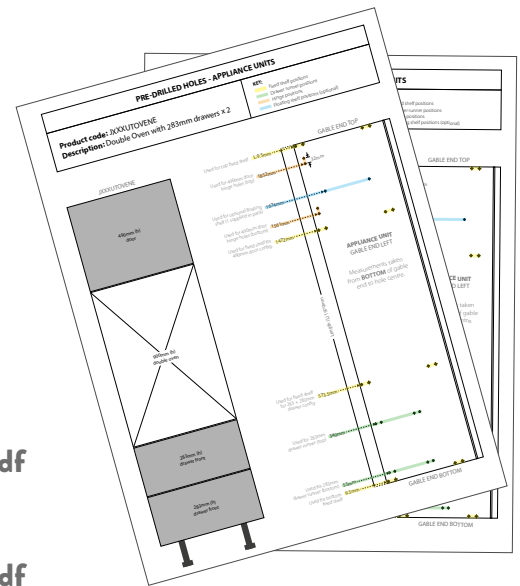

### View 1970mm Appliance Housing:

[www.mkm-kitchentechguides.com/1970mm-appliance-housing.pdf](http://www.mkm-kitchentechguides.com/1970mm-appliance-housing.pdf)

### View 2150mm Appliance Housing:

[www.mkm-kitchentechguides.com/2150mm-appliance-housing.pdf](http://www.mkm-kitchentechguides.com/2150mm-appliance-housing.pdf)

### Configurations included in the appliance housing guides:

#### Appliance Housing

Standard height installation (1970mm)

FF50	FF70	FF90	TOVENA	TOVENB	TOVENC	TOVEND	TOVENE	TOVENF
980	1245	175 895	490	645	490	450	490	645
980	715	895	900	600	380 600	460 600	900	600
			570	715	490	450	283	355
							283	355
150mm plinth								
Fridge / Freezer 50/50 (980 doors)	Fridge / Freezer 70/30	Fridge / Freezer 50/50 (895 doors)	Double Oven	Single Oven	Single Oven & 380 Microwave	Single Oven & 460 Microwave	Double Oven with drawers	Single Oven with drawers

#### Extra Tall Appliance Housing

Extra tall height installation (2150mm)

TFF50	TFF70	TTOVENA	TTOVENB	TTOVENC	TTOVEND	TTOVENE	TTOVENF
175	1245	715	490	570	490	490	715
980	1245	110 600	175 filler 900	380 600	460 600	175 filler 900	110 600
980	895	715	570	570	140 450	283	355
						283	355
150mm plinth							
Fridge / Freezer 50/50	Fridge / Freezer 70/30	Single Oven	Double Oven	Single Oven & 380 Microwave	Single Oven & 460 Microwave	Double Oven with drawers	Single Oven with drawers

## L-shape corners with vertical bi-fold doors

Our L-shape 900 x 900mm base & 600 x 600mm wall units come with 'vertical bi-fold' doors.

Pie Cut and 165° hinges are used for these doors which is included with the cabinet.

Nb. Corner posts not needed for these units.

### How to install vertical bi-fold doors:

1. Attach door 1 to door 2 using the Pie Cut hinges (door 2 comes with pre-drilled holes for hinge cups).
2. Place centre of screw holes for Pie Cut hinge plates **37mm from the front** of door 1, same as when attaching a standard hinge to a cabinet.
3. Attach doors to cabinet with the 165° hinges.
4. Use the additional adjustment screw on Pie Cut hinges to adjust gap between bi-fold doors.

### Hinges (included with cabinet):

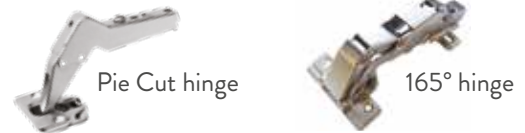

### Hinge positions:

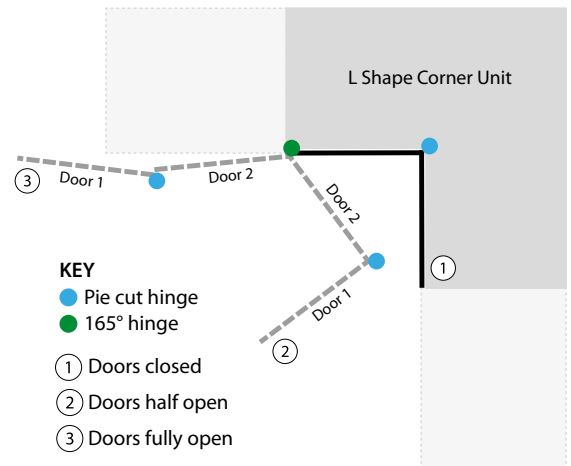

### L-shape corner unit doors:



1. Doors closed



2. Doors half open

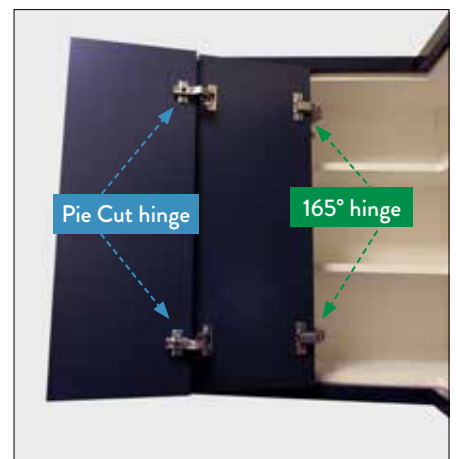

3. Doors fully open

# CABINETS

## Belfast Units

- Our Belfast Sink Units are **600mm wide** to accommodate 600mm wide Belfast sinks (purchased separately).
- Available in **450mm or 490mm height** to allow for undermount or apron installation (see illustration).

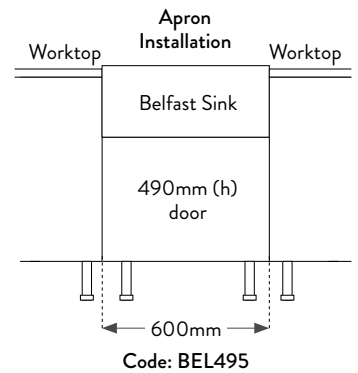
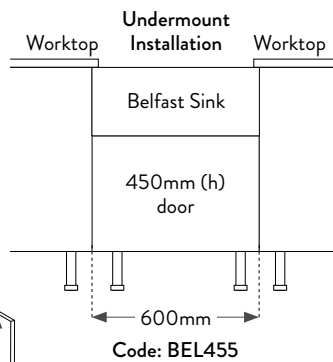
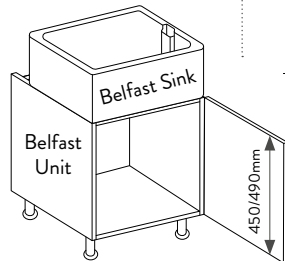

## Boiler Housing

Boilers vary in size & position. Here's how to create your own bespoke housing.

- As boilers are generally deeper than the 300mm depth of our tall wall cabinets you must bring the wall cabinet forward and attach the cabinet to the end panels (min. depth 400mm).
- The end panels need to be securely attached to the wall with L-brackets.

### What you need:

1. Tall Wall Unit 900 x 600mm (leaving back panel out)  
Includes: 900mm height tall wall cabinet with 895 x 596mm door & 110 degree hinges.
2. Base End Panel 900 x 650mm, cut to 900 x 400mm size.  
Optionally use a Tall End Panel 2400 x 650mm cut to size if end panel needs to run down to the worktop.
3. L-brackets

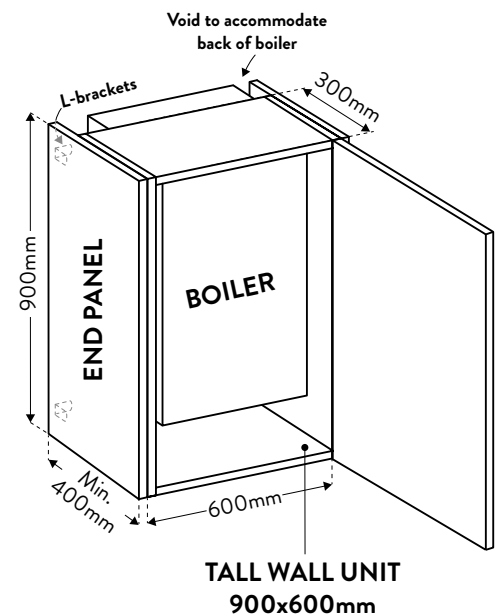

**Please note:** Boilers vary in size and there is no set standard. This will have an effect on filler/door/end panel sizes, please check boiler dimensions carefully prior to installation to ensure the housing is suitable for the boiler it's being used for. It's the installers responsibility to ensure the housing is fitted correctly and in line with boiler safety regulations.

## Bridging Units



- Bridging unit doors are hinged on the top panel of the cabinet.
- The centre of the screw holes for the hinge plates to be placed **37mm from front of cabinet**, the same as for a standard side hinged door.
- 1 x gas lift needed for smaller doors, 2 x gas lifts for larger doors. See 'Door Lifts' tech guide for more info (link below).

View door lifts tech guide here:  
[www.mkm-kitchentechguides.com](http://www.mkm-kitchentechguides.com)

### Hinge hole positions:

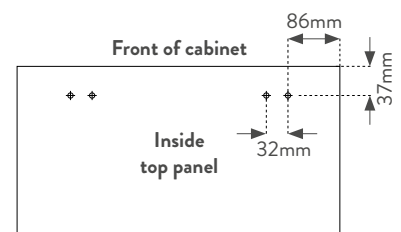



## Wall Microwave Housing

Standard built-in microwaves are deeper than our 300mm deep wall cabinets which means you must bring the wall cabinet forward and install it against an end panel (min. depth 350mm). The end panel needs to be securely attached to the wall with L-brackets. See installation location options overleaf.

**Please note:** Appliance sizes will vary which will have an affect on filler/door sizes. Please check appliance dimensions and specifications carefully prior to purchase/installation to ensure they are suitable for the purpose. It's up to the fitter to ensure the unit is installed correctly and in line with any safety regulations.

### Wall Microwave Housing Kit - 720mm (h)

Order code: JXXXUMICRO60

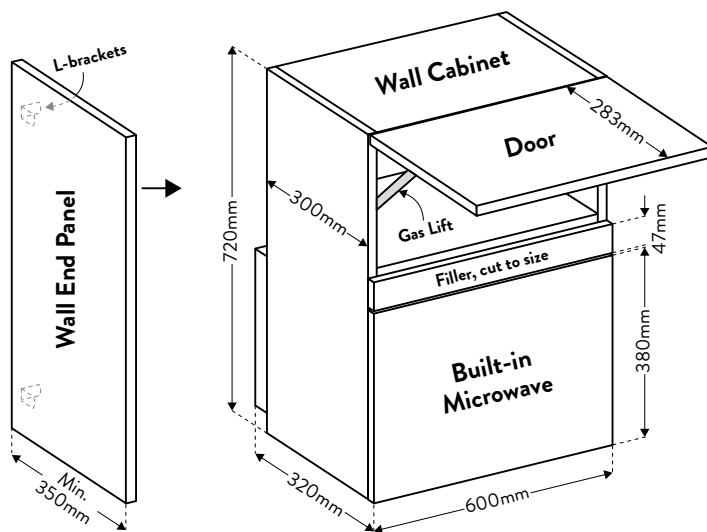

#### What's included:

- Wall Cabinet, 720 x 600mm  
Back panel needs to be cut down to fit above the microwave. Height will vary depending on size of microwave. Holes need drilling for the shelf that sits above the microwave, position variable.
- Door, 283 x 596mm
- Wall End Panel  
Dimensions vary between door ranges, see price list for more info.
- Gas Lift (80 Newton)
- Filler, 110 x 596mm  
Cut filler to approx. 47mm height. **Nb.** Height required will vary depending on size of microwave.
- L-brackets, 25 x 25mm

### Tall Wall Microwave Housing Kit - 900mm (h)

Order code: JXXXUMICRO90

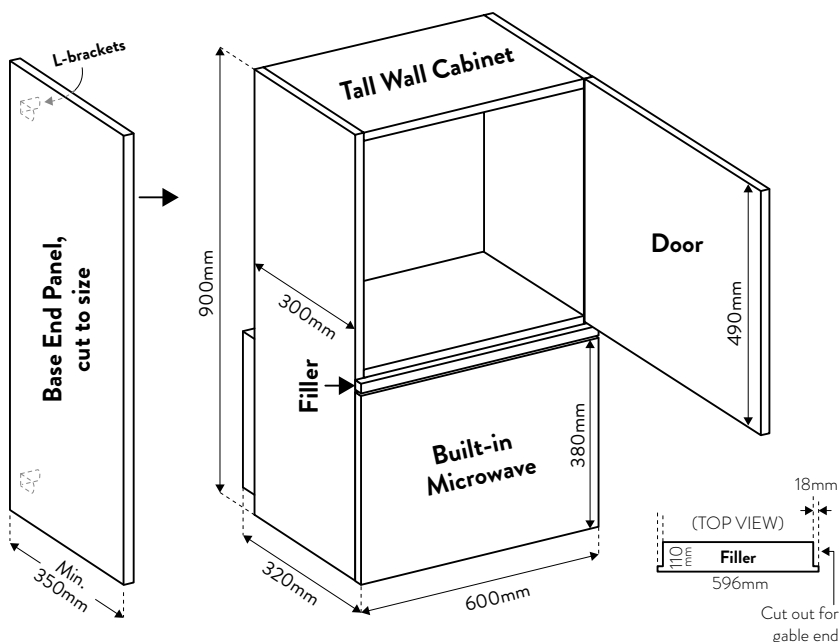

#### What's included:

- Tall Wall Cabinet, 900 x 600mm  
Back panel needs to be cut down to fit above the microwave. Height will vary depending on size of microwave. Holes need drilling for the shelf that sits above the microwave, position variable.
- Door, 490 x 596mm
- Base End Panel, 900 x 650mm  
**Nb.** Base end panel needs to be cut to size.
- L-brackets, 25 x 25mm
- Filler, 110 x 596mm  
Flip filler vertically and make cut-outs for cabinet gable ends (see diagram on the right).

## Wall Microwave Housing

Installation location options

(TOP VIEW)

### Corner Installation

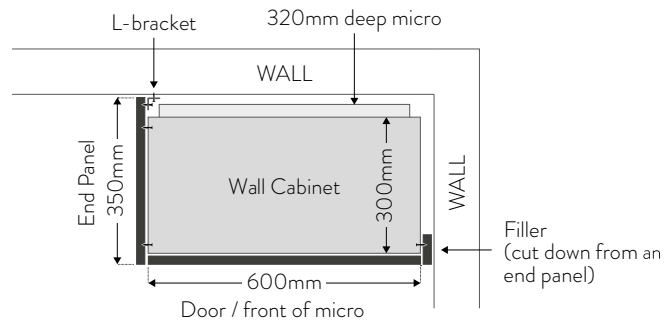

### Installation next to Larder Unit

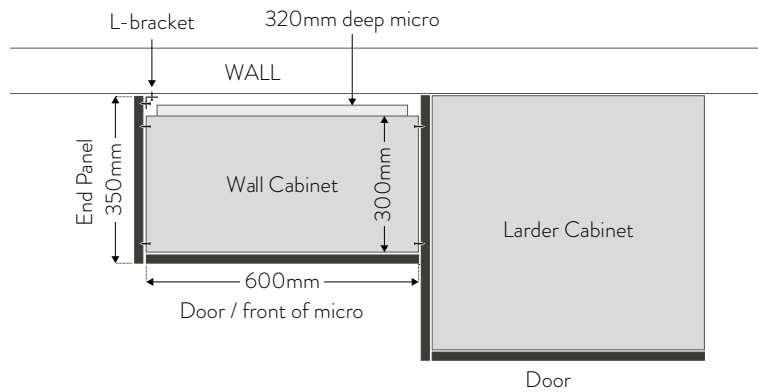

### Installation next to standard Wall Units

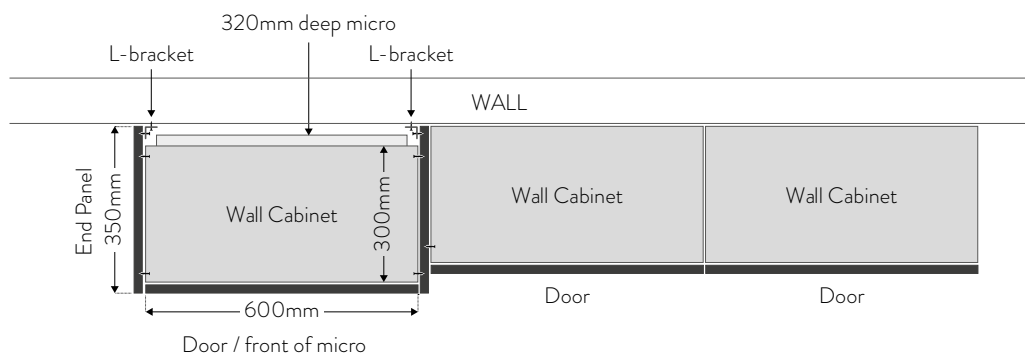

# CORNER PLANNING

## Corner Base Units

All dimensions shown in mm.

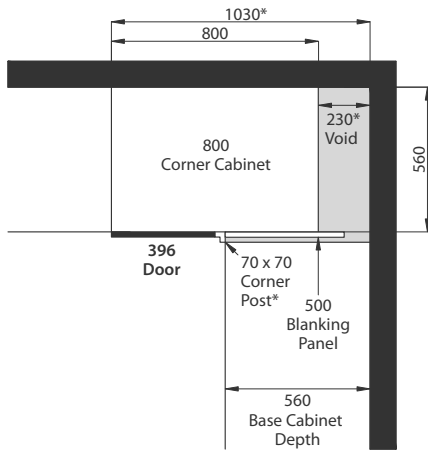

**Product Code:** 80CB4  
**Base Unit:** 800mm (w)  
**Door size:** 396mm (w) x 715mm (h)  
**Blanking panel:** 500mm (w), can be cut to size

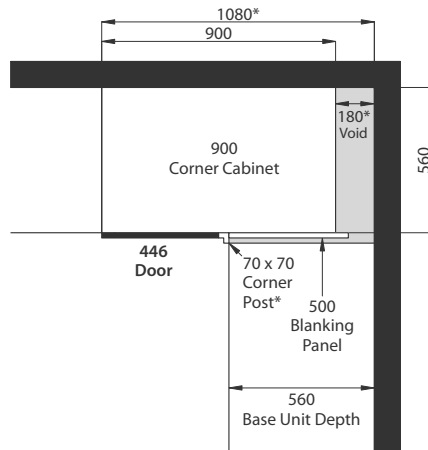

**Product Code:** 90CB  
**Base Unit:** 900mm (w)  
**Door size:** 446mm (w) x 715mm (h)  
**Blanking panel:** 500mm (w), can be cut to size

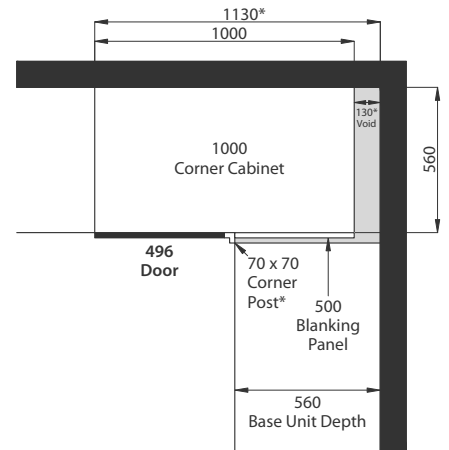

**Product Code:** 10CB5  
**Base Unit:** 1000mm (w)  
**Door size:** 496mm (w) x 715mm (h)  
**Blanking panel:** 500mm (w), can be cut to size

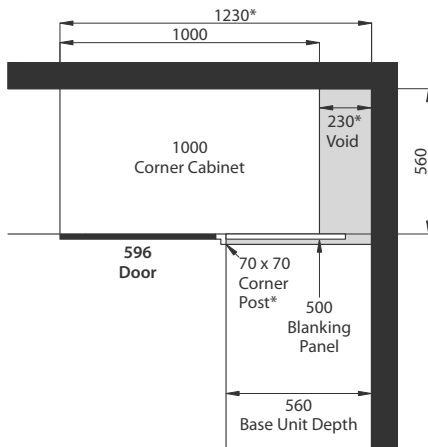

**Product Code:** 10CB6  
**Base Unit:** 1000mm (w)  
**Door size:** 596mm (w) x 715mm (h)  
**Blanking panel:** 500mm (w), can be cut to size

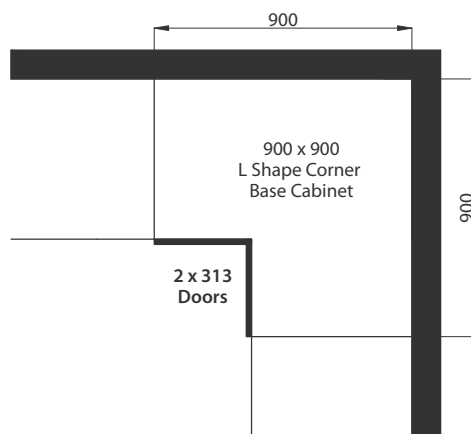

**Product Code:** CBASE  
**Base Unit:** 900 x 900mm L-shape  
**Door size:** 2 x 313mm (w) x 715mm (h)  
**Hinges:** 165° and Pie-cut Corner hinges to be used for the bi-fold corner door

### \* PLEASE NOTE:

Dimensions are based on 70 x 70mm Vivo slab corner post. Corner post sizes vary between ranges which affects the size of the required distance from wall to end of corner cabinet. Please make sure the distance is adjusted to reflect the size of the corner post for the specific door range.

**Eg.** Lucente J-pull corner posts are 60 x 60mm which means distance from wall to end of corner cabinet is 10mm shorter.

Void is covered by the worktop after installation.

## Guide to LH / RH Wirework Corner Units

Units are 'handed' by the side the door is on.

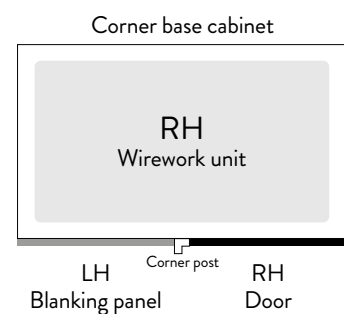
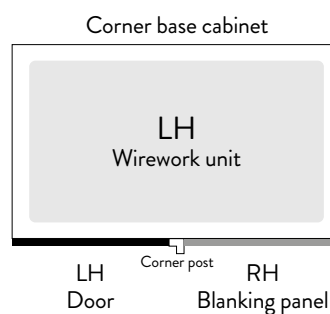

# CORNER PLANNING / CURVED UNITS

## Corner Wall Units

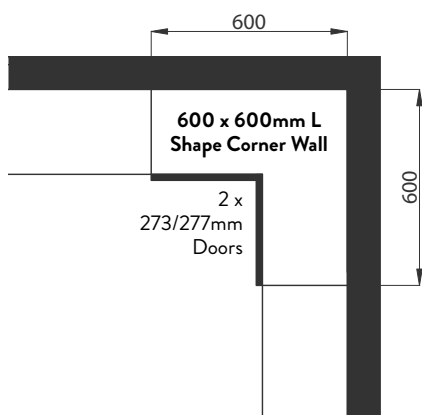

**Product Code:** CWL  
**Wall Unit:** 600 x 600mm L-shape  
**Door size:** 2 x 273/277mm (w) x 715mm (h)  
**Hinges:** 165° and Pie-cut Corner hinges to be used for the bi-fold corner door

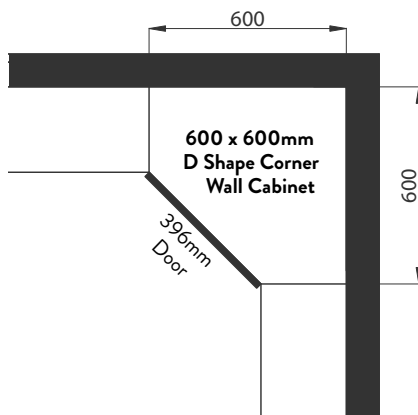

**Product Code:** CWS (720mm) / 9CWS (900mm)  
**Wall Unit:** 600 x 600mm D-shape  
**Door size:** 396mm (w) x 715/895mm (h)

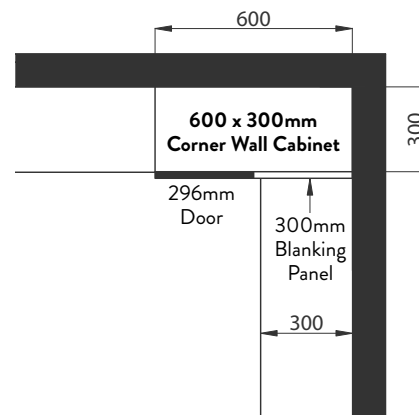

**Product Code:** 30D60W  
**Wall Unit:** 600 x 300mm conventional corner  
**Door size:** 296mm (w) x 715mm (h)

## Curved Units

### Curved Door Heights

Standard installation height (1970mm) & extra tall installation height (2150mm).

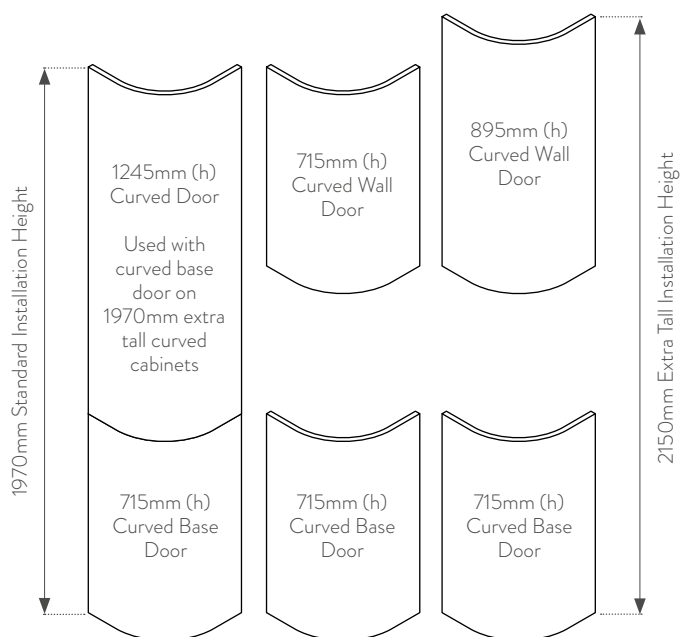

(FRONT VIEW)

### Curved Unit Sizes

#### Curved Base / Extra Tall Units + 260mm Unit

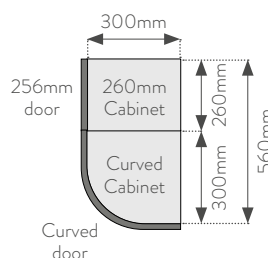

#### Curved Wall Unit

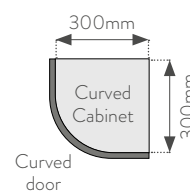

(TOP VIEW)

#### Curved Door Radius

#### Standard Ranges

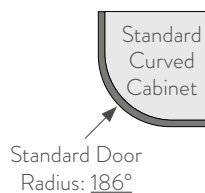

Standard Door Radius: 186°

#### Cartmel Range

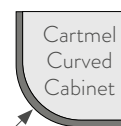

Cartmel Door Radius 168°

(TOP VIEW)

# END PANELS

## Wall End Panel Heights

- Our wall end panels are purposely taller than the height of the standard 720mm (h) wall cabinets so you can **run a cornice and pelmet into them**, as opposed to doing a return on the cornice / pelmet, saving both money and fitting time.
- For 900mm Tall Wall Units without cornice / pelmet: Use a cut-to-size 900mm (h) Base End Panel.
- For 900mm Tall Wall Units with cornice / pelmet: Use a cut-to-size 2400mm (h) Tall End Panel.

### Standard height wall units (720mm) + modern cornice & pelmet:

**CAMBRIDGE / WINDSOR**  
Timber shaker door

**LUCENTE**  
J-pull door

**VIVO+**  
Slab door

**OXFORD**  
1 piece shaker door

**CARTMEL**

Woodgrain effect shaker door

with Square End Cornice / Pelmet

with Square End Cornice / Pelmet

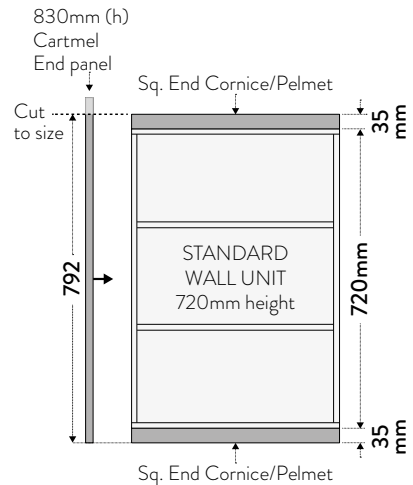
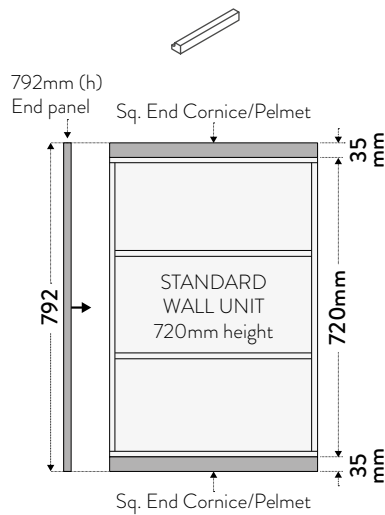

### Standard height wall units (720mm) + traditional cornice & pelmet:

**CAMBRIDGE / WINDSOR**

Real timber shaker door

with Tangent Cornice & Pelmet

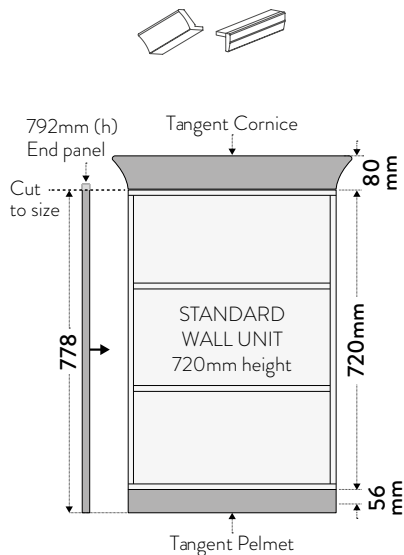

**CARTMEL**

Woodgrain effect shaker

with Tangent Cornice & Pelmet

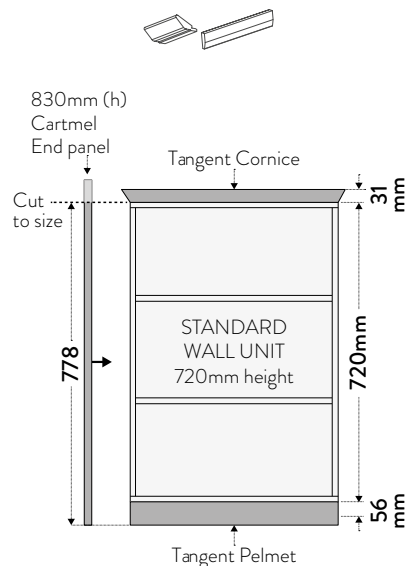

**PORTLAND**

Vinyl shaker door

with Tangent Cornice & Pelmet

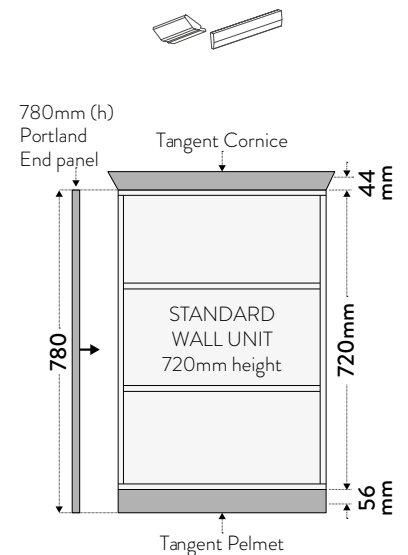

# END PANELS

## End Panel Grain / T&G Direction

### Timber Grain End Panels:

Available in real timber and woodgrain effect ranges.  
See price list for specific sizes available in each range.

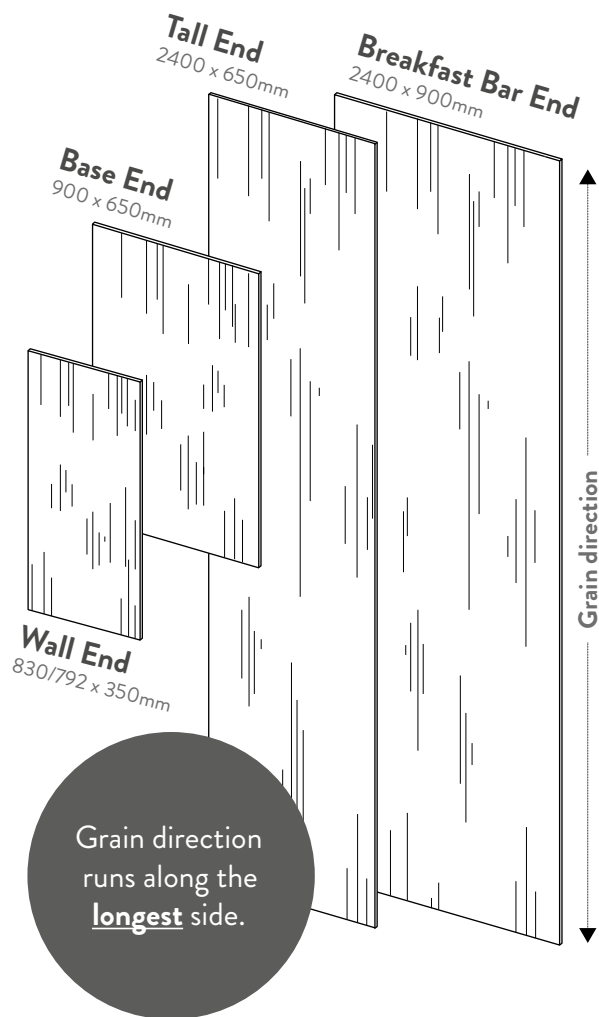

### Tongue & Groove (T&G) End Panels:

Available in shaker door ranges.  
See price list for specific sizes available in each range.

**NB:** T&G end panels are T&G on one side and PLAIN on the reverse (excl. Portland which is T&G on both sides).

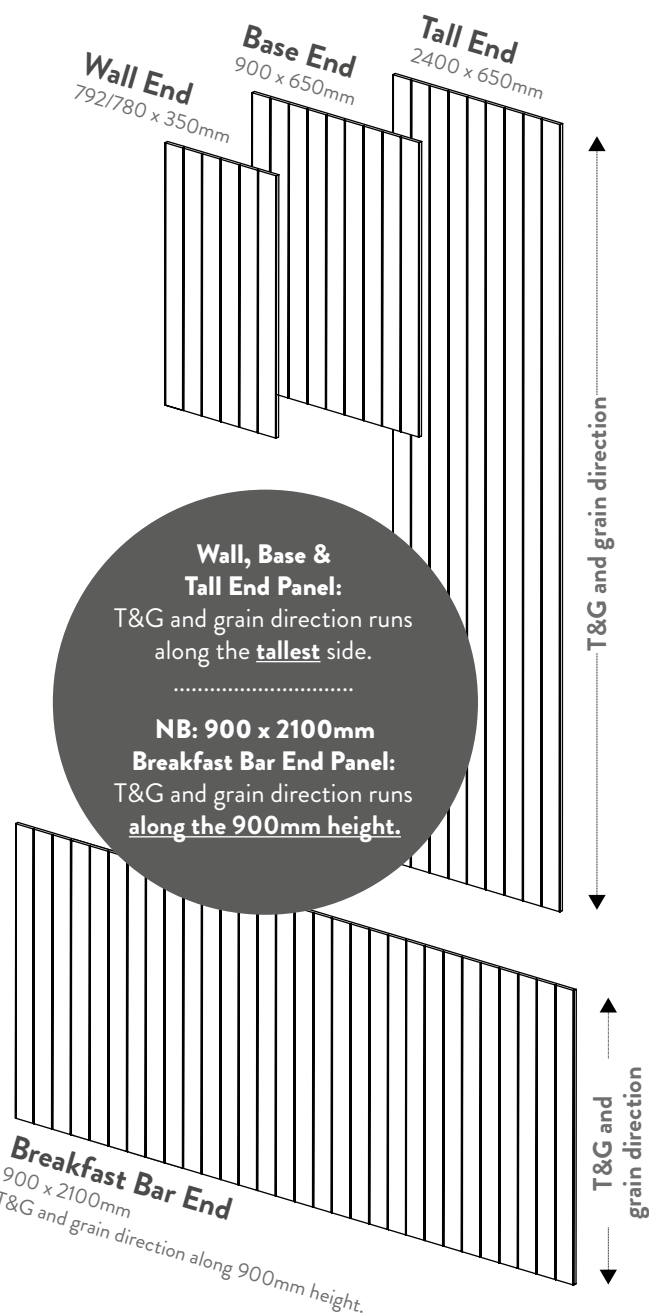

# DRAWERS

## Drawer front marking tool

Our drawer front marking tool is included in all drawer packs and is used to make drawer front installation quicker and easier.



Included with your drawer pack  
Use code 18TOP9060 to order extras

### How to use:

①

Insert the drawer markers into the drawer sides.

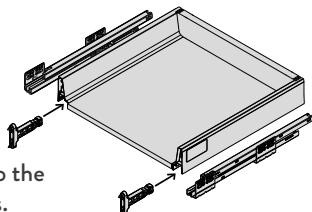

②

Tap the drawer front to create a marker indentation.

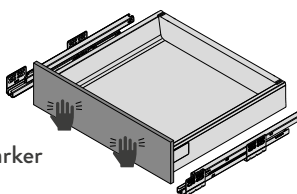

③

Attach the front fixing brackets using the markers as a guide.

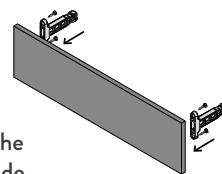

## SmartLarder Installation

The SmartLarder installation instructions include drawer assembly, hinge hole positions and drawer runner positions. Please view using the link below.



### PACK CONTENTS

**1 x Topslide shallow boxed drawer - 83mm**

- 1 Drawer runners (L/R)
- 2 Drawer sides and cover caps (L/R)
- 3 Metal back
- 4 Chipboard base
- 5 Internal brackets (L/R)
- 6 Fascia panel (1100mm lengths, cut to required length)\*

**4 x Topslide boxed pan drawers - 224mm**

- 1 Drawer runners (L/R)
- 2 Drawer sides and cover caps (L/R)
- 3 Metal back
- 4 Chipboard base
- 5 Internal brackets (L/R)
- 6 Glass sides (L/R)
- 7 Front adapters for glass (L/R)
- 8 Rear adapters for glass (L/R)
- 9 Fascia panel (1100mm lengths, cut to required length)\*\*
- 10 Front square rails (1100mm lengths, cut to required length)\*\*
- 11 Side rails (L/R) (Discard any unused rails)

\* Fascia panel cutting dimensions: 467mm (Internal cabinet width - 97mm)  
NB: You will receive extra parts within your pack. Only the components pictured will be needed to construct your SMARTLARDER. Any extras can either be discarded or kept as spare parts.

\*\* Front square rail cutting dimensions: 501mm (Internal cabinet width - 63mm)

Dimensions taken from base, using a 1970mm tall carcass.

View SmartLarder installation guide here:  
[www.mkm-kitchentechguides.com](http://www.mkm-kitchentechguides.com)

# DRAWERS

## Internal Drawers

### Internal drawer unit:

(SIDE VIEW)

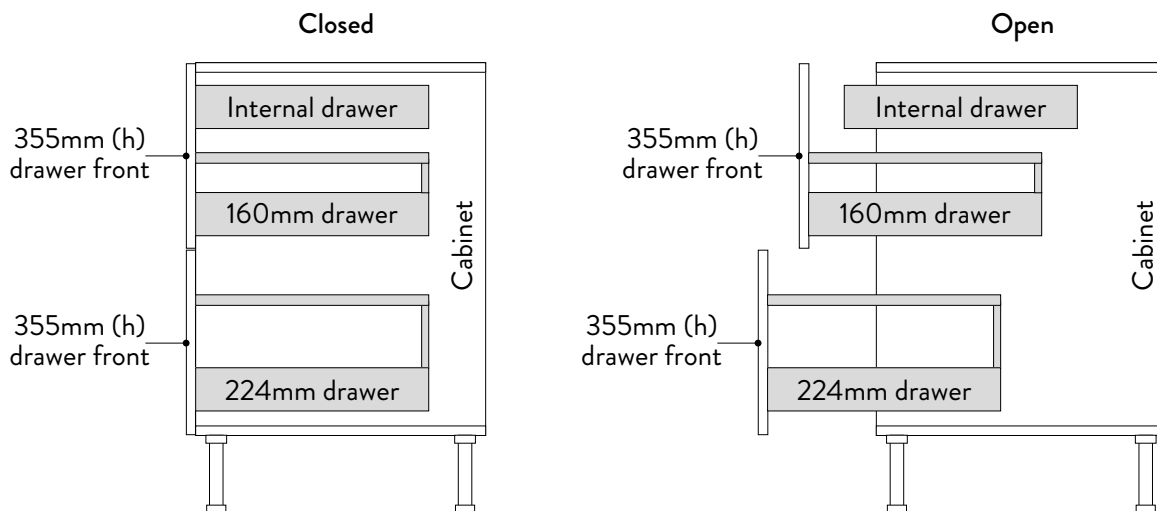

### Internal drawer contents:

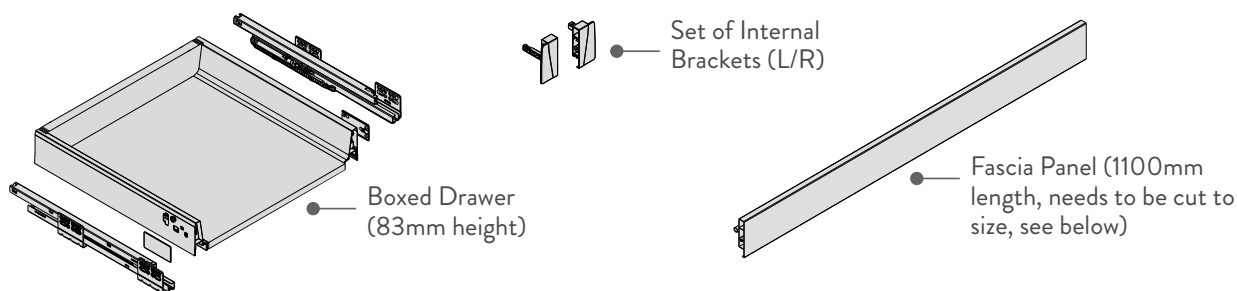

### How to assemble & install:

1. Cut Fascia Panel to size, see cutting dimensions on the right.
2. Attach Internal Brackets to Fascia Panel using the supplied screws, then push into place onto the front of the boxed drawer.
3. Install the internal drawer in the cabinet like a regular drawer.

### Fascia Panel cutting dimensions:

**Internal cabinet width, minus 97mm.**

Eg. for 600mm wide unit, cut fascia panel to 467mm.

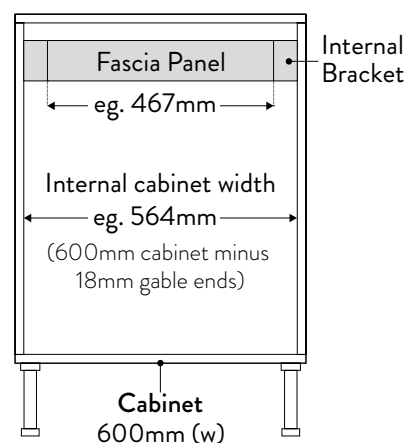

(FRONT VIEW)

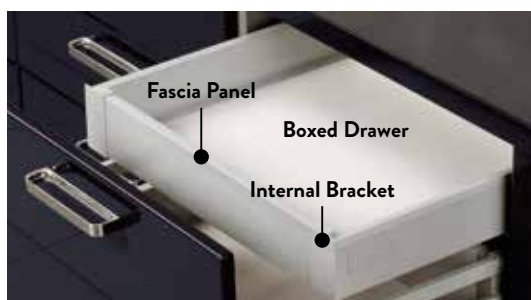



## Drawer runner positions

### Drawerline / 2 drawer / 3 drawer / internal drawer packs:

Use the pre-drilled holes on our cabinets to attach your drawer runners, using the Euro screws included with the drawer.

Pre-drilled holes for 1, 2 & 3 drawer configs.

#### Pre-drilled holes for drawer runners:

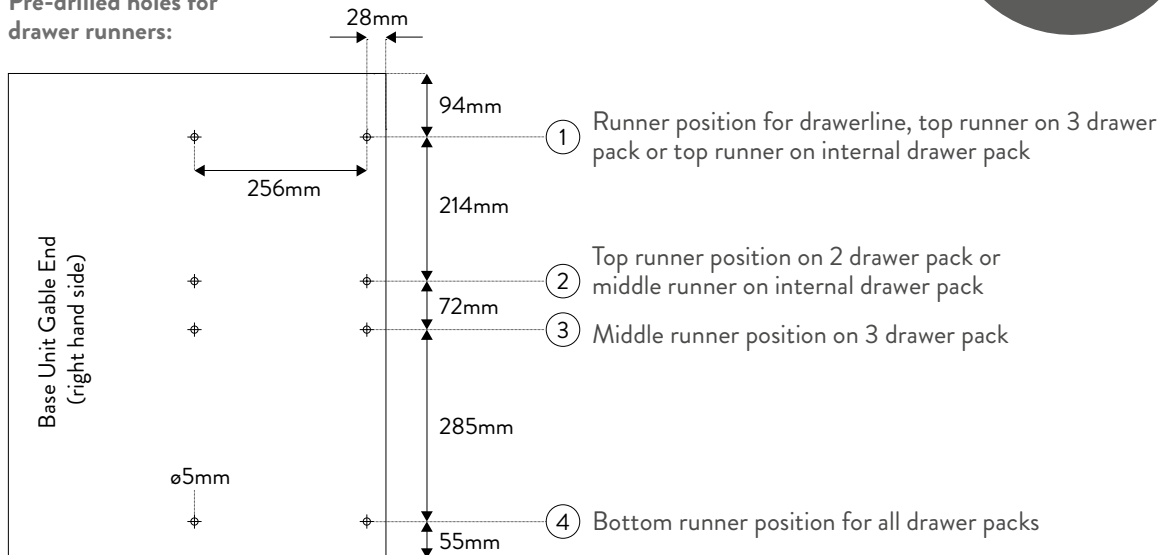

### 4 drawer / 5 drawer packs:

These drawer combinations require holes drilling for the drawer runners. Use the drawer runner template included in the drawer pack to help position the holes correctly.

#### Drawer runner template:

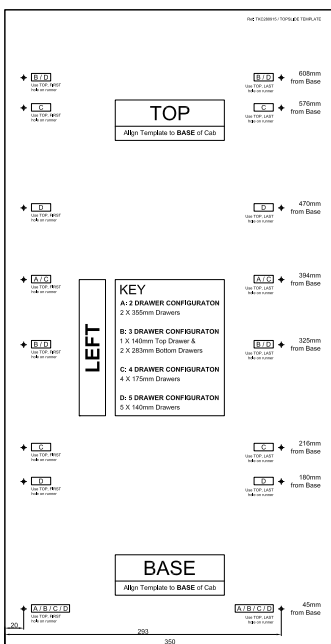

#### Positioning the template:

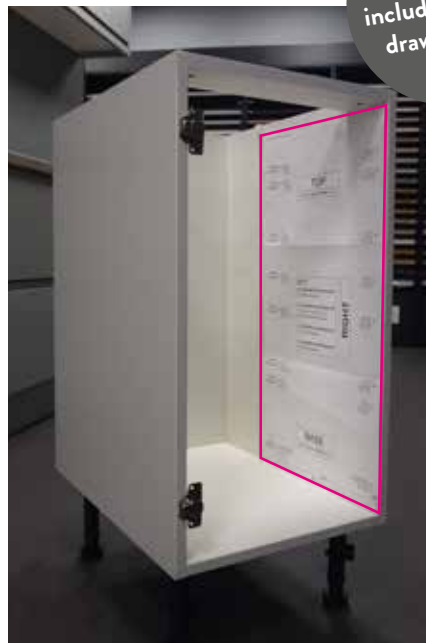

Template included with all drawer packs

#### How to use the template:

1. Align template with bottom and front of cabinet. Use 'LEFT' template on left hand side of cabinet and 'RIGHT' template on right hand side of cabinet.
2. Choose drawer configuration required and use the key to identify the positions of the holes needed for the drawer runner screws.